

2024

MINNESOTA STATE FAIR FFA SAFE TRACTOR OPERATOR'S CONTEST

1. **Eligibility.** Winners of the FFA Champions trophy are ineligible to compete in the FFA Safe Tractor operators contest.
 - A. Each contestant must have reached their 14th birthday but not their 19th birthday by the opening day of the Minnesota State Fair.
 - B. **Must have a state drivers license or learners permit in their possession. Contestants under age for a regular driver's license or permit must have IN THEIR POSSESSION the new exemption certificate authorized under the U.S. Department of Labor order on Hazardous Occupations in Agriculture.**
 - C. Each contestant in the state contest **MUST REPRESENT** an FFA chapter.
 - D. **Three FFA members per chapter** may enter. Each FFA entrant must be certified by their chapter advisor as having been the winner or runner-up over at least three other FFA contestants in a contest designed and operated to approximate the state contest.
 - E. The scores of three members will be combined for a team score.
 - F. Wisconsin FFA members in sections 1, 2, and 3 are eligible to enter and compete.
2. The contest is a one-day event, held Friday, Aug. 30. Registration begins 3:30 p.m. in the Compeer Arena; written examination at 4:15 p.m., followed by Safety and Maintenance check, two-wheel driving event and four-wheel driving event at the West practice ring.
3. **Awards.**
 - A. **Ribbons.** FFA contestants that complete all five events will be awarded a ribbon: blue, red, or white, based on their performance.
 - B. **Trophies.** The FFA champion and reserve champion tractor operators will each be awarded trophies.

MINNESOTA STATE FAIR

FFA SAFE TRACTOR OPERATOR'S CONTEST

RULES AND INFORMATION

A. PURPOSE.

To promote and encourage safe and skillful farm tractor operation.

B. ELIGIBILITY.

Previous winners of the Champions Trophy and Sponsors are not eligible to compete in the State Safe Tractor Driving Contest.

Each contestant must have reached their 14th birthday, but not their 19th birthday by January 1 of the year of the contest.

Each contestant must have a state driver's license or learner's permit in his/her possession.

Contestants under age for a regular driver's license or permit must have in their possession the exemption certificate authorized under the U.S. Department of Labor order on hazardous occupations in agriculture.

Each contestant in the state contest must represent an FFA Chapter. Three (3) FFA members per chapter may be entered in the State FFA Safe Tractor Driving Contest. Each FFA entrant must be certified by a chapter adviser as having been the winner over at least three (3) other FFA contestants in a contest designed and operated to approximate the state contest.

C. ENTRY PROCEDURE.

Contestants must complete the official contest application included in this book. Entries must be mailed to the contest coordinator. No entries will be accepted unless post marked on or before the Monday prior to the opening day of the fair.

Where local contests are scheduled too late to make the deadline, a reservation must be arranged before the Monday prior to the opening day of the fair.

The large number of contestants in recent state contests makes it necessary to refuse to accept late entries without advance reservations.

D. OUTLINE OF CONTEST EVENTS.

1. Written Examination
2. Tractor Safety
3. Practical Examination (routine daily check-up)
4. Two-wheel Driving Event
5. Four-wheel Driving Event

E. AWARDS.

All FFA contestants completing all five (5) events will be awarded a ribbon based on performance (blue = 1st, red = 2nd, white = 3rd).

The FFA champion and reserve champion tractor operators will each be awarded a trophy based on performance.

F. TRANSPORTATION, ACCOMMODATION AND MEALS.

Contestants should arrange their transportation through the person certifying their entry. A noon lunch will be provided for contestants.

G. TRACTOR SELECTION.

New tractors will be provided by manufacturers for the state contest. The tractors may be either two-wheel drive or front-wheel assist (FWA).

A short practice period will be allowed before each section of the contest on a tractor similar to the one used in that section or event (under the guidance of the manufacturer's representative), so each contestant can acquire the "feel" of the tractor to be used. Contestants will be briefed in small groups on the controls and operation of each type of tractor before being allowed to drive in the practice session. Contestants will not be allowed to drive in a contest event with a particular tractor until they have satisfied the manufacturer's representative that they can safely handle the tractor in question. Contestants will not be allowed to drive through any part of the contest course during practice.

H. SCORING.

The penalty scoring system will be used. Placing will be based on the total number of penalty points accumulated. The highest placing will go to contestants with the lowest scores. Each event will have a time limit, and contestants will be stopped when time is called.

Written Examination. Each unanswered question and each incorrect answer will draw 20 penalty points. No penalty points will be accumulated for time used, but all contestants will be stopped at the end of the 30-minute time limit.

Practical Examination (routine daily safety & maintenance check-up). Undetected items needing attention and incorrect items indicated by contestants as needing correction will each add 50 penalty points. Penalty points will not accumulate for time used in this event, but safety violations will add penalty points.

Driving Events. Penalty points for safety violations, hit markers, etc. during driving events will be so severe that the importance of speed will be minimized. Contestants will be stopped if they do not complete any particular event within the time limit. Penalty points for the time used (one per second) will accumulate in each of the driving events.

The individual event scoring and layout sheets outline time and measurement scoring details. **The penalty points accumulate for time used plus those from final measurements, will not exceed 520 points for any one driving event.** Penalty points assessed for safety violations and hit markers are assigned separately and will be added to the 520-point maximum for each event.

Measurement System. Two and Four wheel events: penalty points for these events will depend on the contestant's progress through the course at the time the four (4) minute limit is reached. See the appropriate Scoring Guide Sheet for details.

I. JUDGES AND RULES INTERPRETATION COMMITTEE.

One of the judges in each event will be designated as head judge. Judges will be assigned to specific events. A rules interpretation committee will handle all problems of rules interpretations arising before or during the contest. The rules interpretation committee reserves the right to make revisions depending on contest condition. No questions will be considered if submitted later than 14 minutes after the last contestant has finished the events in question. Decisions of the rules interpretation committee are final. Competition of this committee will consist of the Contest Superintendent, the head judge of the event in question, and one other head judge.

All rules and registration inquiries should be sent to the Assistant Superintendent in charge of this contest. Completed entry forms and request for additional contest rules and judging forms should be directed to: Minnesota State Fair, Competition Dept. / FFA Tractor Driving, 1265 Snelling Ave. N., St. Paul, MN 55108

References:

American Association for Vocational Instructional Material

Safe Tractor Operation and Safety Care

Selecting and Storing Fuels and Lubricants

John Deere

Fundamentals of Machine Operation

Tractors Safety Preventive Maintenance

Minnesota Extension Service, 3 Coffey Hall, St. Paul MN

Safe Operation of Agricultural Equipment 4H-BU-0307.

DESCRIPTION OF EVENTS

A. WRITTEN EXAMINATION - 30 MINUTES.

50 multiple choice questions covering safety and technical applications. 20 penalty points assessed for each question unanswered or answered incorrectly.

B. PRACTICAL EXAMINATION (ROUTINE DAILY CHECK-UP) - 4 MINUTES.

Inspection of tractor for maintenance and safety items. Basis for selecting items will be a routine daily check-up. Contestants must be prepared to diagnose either gasoline or diesel fueled tractors. Tractors are not to be started by contestants. Exam will be conducted away from the driving event site, and give to one contestant at a time.

A new tractor will be used, with faulty items prepared by the judges preceding the contest. No more than 10 items will be wrong or faulty.

Contestant will not be allowed to inspect the contest tractor prior to the exam. They will be permitted to ask questions about the location of specific tractor parts prior to taking the exam. (See scoring sheet for more information.)

Contestants will indicate to the judges each item he/she finds needing correction, based on good tractor maintenance or safety principles.

C. TWO WHEEL EVENT - 4 MINUTES.

D. FOUR WHEEL EVENT - 4 MINUTES.

Special conditions common to each of the driving events: when ready to begin driving (gear shift in park or neutral; engine idling; brakes locked if tractor equipped with brake locking system; PTO disengaged), contestant must notify timing official. Judge will give starting signal and timing will begin.

Upon starting signal, contestant will drive the course outlined in this book. After backing into the shed, gear must be moved to park (or neutral, with clutch engaged and brakes locked), and engine turned off. Timing ends when engine is shut off. (See Two Wheel Event Scoring Sheet and Scoring Guide Sheet, and Four Wheel Event Scoring Sheet and Guide for more information.)

E. SAFETY.

Rules listed will apply in this contest. Contestants will be scored on safety any time they are operating tractors. This included the practice period as well as before, during and after the practical examination and driving events.

SAFE TRACTOR DRIVING RULES

The following rules are offered as a guide for safe tractor operation. Safety judges will be guided by, but not limited to, the scope or coverage of the following:

1. When mounting tractor, set brakes or place gear shift lever in park position before starting engine. Tractor equipped with a shift lever and clutch should have shift in neutral, disengage clutch, and lock brakes.
2. Place PTO lever in neutral before starting engine. PTO should be disengaged at all times except when in use.
3. Start and stop gently. Avoid careless or sudden starts and stops which tend to "bounce" front wheels off the ground, or cause rear wheels to "dig in".
4. When contest tractor is equipped with clutch, contestant must avoid unnecessary slipping of the clutch. Operator's foot or hand may remain on clutch, but "riding" the clutch is to be avoided.
5. Release brakes before driving tractor.
6. Tractor should be kept in gear while driving. Never shift into neutral or disengage clutch to coast part of the way.
7. Ride on tractor seat or stand on platform. Never ride on drawbar or hitch of implement being drawn.
8. Reduce speed to safe level before making a turn or applying one brake.
9. Drive tractor at speeds slow enough to ensure safety for yourself and contest officials.
10. Avoid short turns, which will foul implement against tractor wheel.
11. Do not permit extra riders on tractor at any time.
12. Bring tractor to a complete stop before dismounting.
13. Mount and dismount tractor properly; use steps if provided by manufacturer.
14. Lock brakes before dismounting. Shift lever must be moved to park position on tractor **not** equipped with a brake locking system.
15. Road gear should not be used during the practice or driving periods. Any gear that will permit ground speed of 10 miles per hours or greater will be considered road gear.
16. When leaving tractor, move shift lever into park position (or neutral, with clutch engaged), set brakes and turn off engine. (The sequence of the operation does not necessarily need to be followed so long as all operations are accomplished in a safe manner.)
17. Clothing should have snug fitting cuffs. Avoid loose fitting or baggy clothing.
18. Smoking will not be permitted, in accordance with the FFA Code of Ethics.

PRACTICAL EXAMINATION

Routine Daily Check-up Maintenance and Safety Scoring Sheet

Name of Judge _____

Contestant # _____

Score _____

Judge will select ten (10) items and set up tractor accordingly. Either diesel or gasoline fueled unit may be used, depending on availability, etc.).

Suggested or sample items (these will not be provided at the contest)

1. Air cleaner needs cleaning
2. Air cleaner oil level low
3. Air cleaner cartridge needs replacement
4. Air intake clogged
5. Battery cables loose
6. Battery level low (one or more cells)
7. Brakes not set and locked
8. Crankcase oil level low
9. Distributor cap loose or not properly in place
10. Fan or power steering belt loose
11. Fuel filter needs replacement
12. Fuel tank cap missing
13. Hydraulic systems fluid level low
14. Injector line leaking
15. Light or lights not operational
16. Radiator cover not properly attached
17. Radiator level low
18. Safety lights not operable
19. Seat dangerously loose
20. Sediment bowl needs cleaning
21. Spark plug wire disconnected
22. Tire pressure low (visually evident)
23. Transmission not in neutral
24. Transmission oil level low
25. Other

SCORING

Fifty (50) points for each item missed or incorrectly listed. Contestants must be stopped at the end of four (4) minutes, but no penalty points will accumulate for time used.

Number of items missed or incorrectly listed x 50 = (score).

Time: _____ # minutes _____ # seconds

Time: _____ # minutes _____ # seconds

TWO WHEEL EVENT Scoring Sheet

Name of Judge _____

Contestant # _____

Score _____

1. Golf balls dislodged _____ x 50 = _____

2. Knocking stake out of line (so ball will not stay on top)
Additional penalty. Contestant will be disqualified for driving over
any portion of contest stake or line rather than reversing direction
to clear tractor or implement. _____ x 100 = _____

3. Tractor engine stalled _____ x 10 = _____

4. Time penalty (240 pt. max) [total seconds] _____ x 1 = _____

Time: _____ # minutes _____ # seconds

5. Distance (280 pt. max.) or progress through course [see Two Wheel event scoring diagram]

Zone I 280 pt. x 1 = _____

Zone II 200 pt. x 1 = _____

Zone III 120 pt. x 1 = _____

Zone IV 120 pt. max.

Distance (over 2 inches) between implement and closest of the two (2) rear stakes.

SAFETY SCORE _____ x 10 = _____

TOTAL PENALTY POINTS _____

TWO WHEEL EVENT COURSE LAYOUT

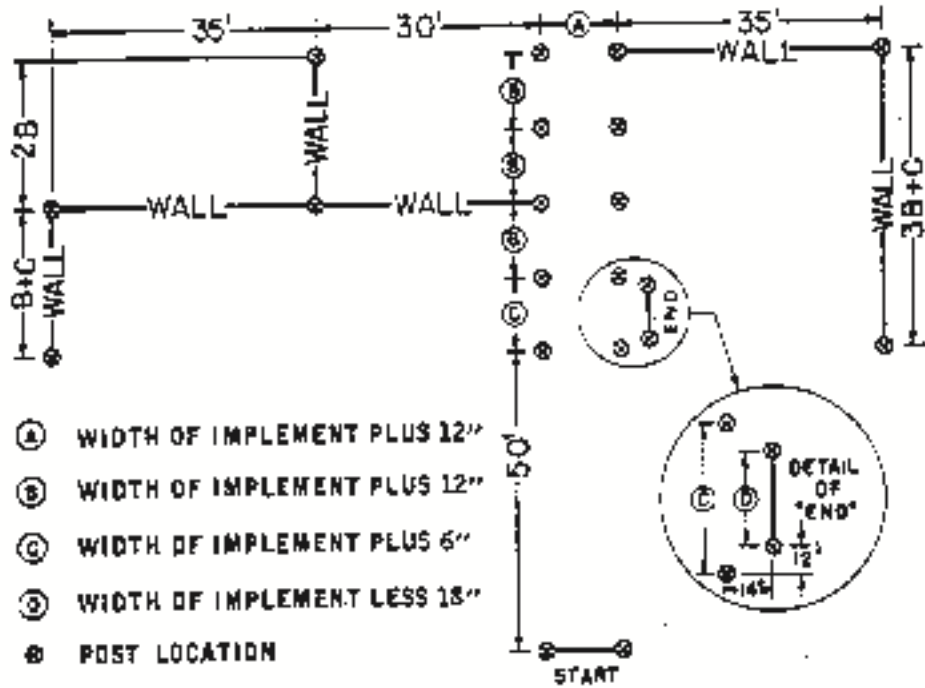

TWO WHEEL EVENT SCORING DIAGRAM

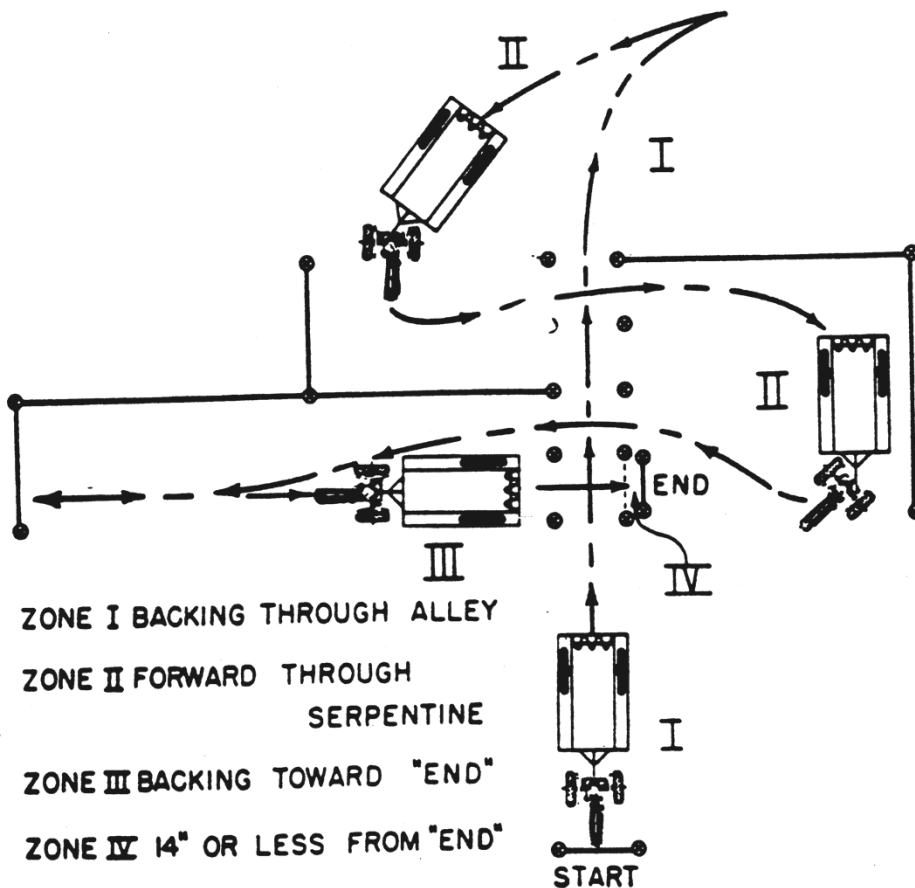

FOUR WHEEL EVENT Scoring Sheet

Name of Judge _____

Contestant # _____

Score _____

1. Golf balls dislodged _____ x 50 = _____

2. Knocking stake out of line (so ball will not stay on top)
Additional penalty. Contestant will be disqualified for driving over
any portion of contest stake or line rather than reversing direction
to clear tractor or implement. _____ x 100 = _____

3. Tractor engine stalled _____ x 10 = _____

4. Time penalty (240 pt. max) [total seconds] _____ x 1 = _____

Time: _____ # minutes _____ # seconds

5. Distance (280 pt. max.) or progress through course [see Two Wheel event scoring diagram]

Zone I 280 pt. x 1 = _____

Zone II 200 pt. x 1 = _____

Zone III 120 pt. x 1 = _____

Zone IV 120 pt. max.

Distance (over 2 inches) between implement and closest of the two (2) rear stakes.

SAFETY SCORE _____ x 10 = _____

TOTAL PENALTY POINTS _____

TRACTOR OPERATOR'S CONTEST

Safety Scoring Sheet

Name of Judge _____

Contestant # _____

	Practice	II	III	IV	Score	_____
Starting tractor while in gear	_____	_____	_____	_____	x 50	_____
Failure to disengage clutch when starting engine	_____	_____	_____	_____	x 25	_____
Failure to disengage PTO when starting engine	_____	_____	_____	_____	x 50	_____
Failure to engage clutch gently *	_____	_____	_____	_____	x 25	_____
Skidding or spinning	_____	_____	_____	_____	x 100	_____
Fouling the implement	_____	_____	_____	_____	x 50	_____
Operating at unsafe speeds	_____	_____	_____	_____	x 100	_____
Moving tractor with one or both wheel brakes locked	_____	_____	_____	_____	x 10	_____
Failure to shift into park (or neutral with clutch engaged) before dismounting	_____	_____	_____	_____	x 100	_____
Failure to lock brakes before dismounting *	_____	_____	_____	_____	x 100	_____
Failure to bring tractor to a full stop before dismounting	_____	_____	_____	_____	x 100	_____
Smoking	_____	_____	_____	_____	x 100	_____
Other (list or explain)	_____	_____	_____	_____	x	_____

TOTAL PENALTY POINTS _____

* Where possible: i.e. within limitations of the condition or design of contest tractor.

STAKE PLAN FOR TRACTOR OPERATORS CONTEST

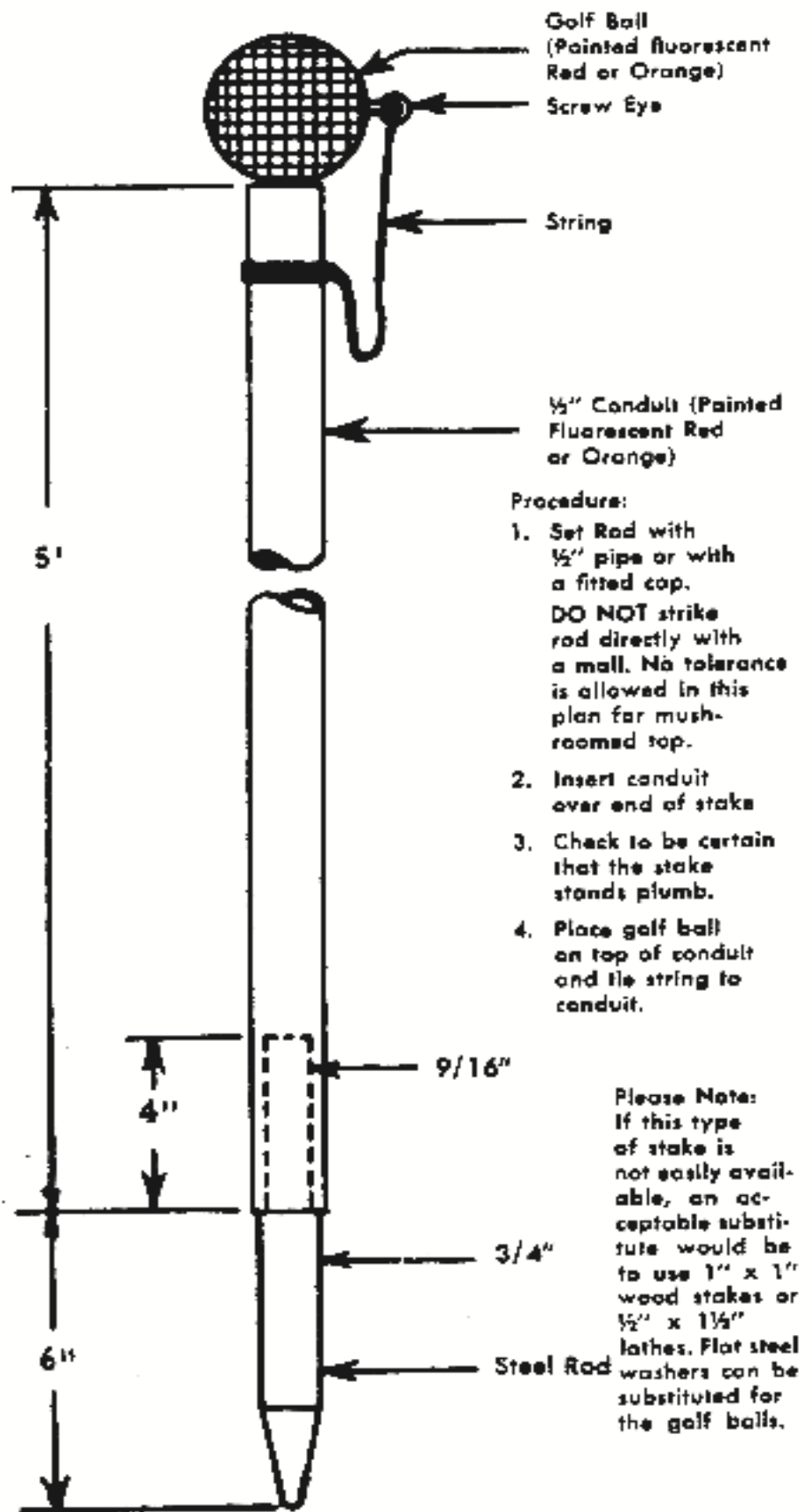

MINNESOTA FFA SAFE TRACTOR OPERATORS CONTEST APPLICATION

Name

(Last) (First) (MI)

Birthdate _____ Age (at contest time) _____

State Drivers License or Learners Permit No. _____

Child Labor Law Exemption Certificate No. _____

Parent/Guardian

(Last) (First) (MI)

Contestant's Home Address

City _____ Zip Code _____

Representing _____ FFA Chapter (City) _____

SAFETY PLEDGE

I hereby agree to abide by all rules of safe and prudent conduct during this contest. I realize that I may be disqualified by any contest official for any violation endangering contest officials, spectators, other contestants, or myself.

Signed _____

(Contestant)

CERTIFICATION

I hereby certify that this contestant has met the eligibility requirements as set forth in the current Minnesota Safe Tractor operators Contest Bulletin and that _____ contestants from our local chapter competed in an elimination contest. Our contest was held at _____ on _____

Signed (Ag. Instr) _____ Date _____

School _____

City _____ Zip Code _____

MAILING INSTRUCTIONS

All entries MUST BE POSTMARKED on or before the Monday prior to the opening day of the State Fair. (Where local contests must be scheduled too late to make this deadline, an advance reservation must be arranged.)

Mail entries to: FFA Safe Tractor Operators Contest Minnesota State Fair - Competition Department
1265 North Snelling Avenue Saint Paul, Minnesota 55108.

